



Most Widely Accepted and Trusted

ESR-2306

Reissued 08/2018

This report is subject to renewal 08/2020.

ICC-ES Evaluation Report

ICC-ES | (800) 423-6587 | (562) 699-0543 | www.icc-es.org

DIVISION: 05 00 00—METALS

SECTION: 05 10 00—STRUCTURAL METAL FRAMING

REPORT HOLDER:

FLEX-ABILITY CONCEPTS

EVALUATION SUBJECT:

FLEX-C TRAC AND FLEX-C ANGLE



“2014 Recipient of Prestigious Western States Seismic Policy Council (WSSPC) Award in Excellence”



ICC-ES Evaluation Reports are not to be construed as representing aesthetics or any other attributes not specifically addressed, nor are they to be construed as an endorsement of the subject of the report or a recommendation for its use. There is no warranty by ICC Evaluation Service, LLC, express or implied, as to any finding or other matter in this report, or as to any product covered by the report.



ICC-ES Evaluation Report

ESR-2306

Reissued August 2018

This report is subject to renewal August 2020.

www.icc-es.org | (800) 423-6587 | (562) 699-0543

A Subsidiary of the International Code Council®

DIVISION: 05 00 00—METALS

Section: 05 10 00—Structural Metal Framing

REPORT HOLDER:

FLEX-ABILITY CONCEPTS

EVALUATION SUBJECT

FLEX-C TRAC AND FLEX-C ANGLE

1.0 EVALUATION SCOPE

Compliance with the following codes:

- 2012 and 2009 *International Building Code*® (IBC)
- 2012 and 2009 *International Residential Code*® (IRC)

Properties evaluated

Structural

2.0 USES

The Flex-C Trac is a segmented U-shaped metal track used as top and bottom tracks for interior and exterior load-bearing and non-load-bearing walls framed with light gage cold-formed steel studs.

The Flex-C Angle is a segmented angle-shaped metal track used for non-load-bearing walls framed with light gage cold-formed steel studs.

3.0 DESCRIPTION

3.1 General:

Table 1 lists the part numbers, nominal web depths, minimum base-steel thicknesses, and fasteners for Flex-C Tracs and Angles.

3.1.1 Flex-C Trac: Flex-C Tracs are manufactured with a web depth for 2¹/₂-, 3⁵/₈-, 4-, 6-, 8-, and 10-inch-deep (63.5, 92, 102, 152, 204, and 254 mm) wall framing studs. Each 2¹/₂-20L, 3⁵/₈-20L, 2¹/₂-20, 3⁵/₈-20, and 6.0-20 Flex-C Trac is an assemblage of Flex-C Trac segments factory-interconnected by pivot joints and “Hammerlock” tabs with steel straps woven through, but not factory-connected to, both flanges of the Flex-C Trac segments. The pivot joints are integrally formed, swaged eyelets. The pivot joints, “Hammerlock” tabs, and the ability of the steel straps to slide through the flanges of the Flex-C Trac segments, permit tracks to be formed for use in straight walls and curved walls. The final configuration (straight or curved) of the track is fixed by field-installed fasteners to mechanically attach the steel straps to Flex-C Trac flanges or by activating

“Hammerlock” tabs prefabricated in the overlapping portion of the webs of the steel channel segments. The remainder of the Flex-C Tracs are similar to the 2¹/₂-20L, 3⁵/₈-20L, 2¹/₂-20, 3⁵/₈-20, and 6.0-20 Flex-C Tracs; except these Flex-C Tracs have integral straps extended from flanges of the Flex-C Trac segments. Figure 1 shows a typical drawing of Flex-C Trac and assembly of Flex-C Tracs connected with steel straps. Figure 2 shows a typical drawing of Flex-C Trac having integral straps and assembly of Flex-C Tracs connected with the integral straps.

3.1.2 Flex-C Angle: The 2¹/₂-20L, 2¹/₂-20, and 3⁵/₈-16 Flex-C Angles are similar to the 2¹/₂-20L, 2¹/₂-20, and 3⁵/₈-16 Flex-C Tracs, except the Flex-C Angles consist of curvable angle segments (rather than channel segments). Each 2¹/₂-20L and 2¹/₂-20 Flex-C Angle is an assemblage of Flex-C Angle segments factory-interconnected by pivot joints and “Hammerlock” tabs with a steel strap woven through, but not connected to, the side flange of the angle. The pivot joints are integrally formed, swaged eyelets. The pivot joints, “Hammerlock” tabs, and the ability of the steel straps to slide through the channel flanges, permit the track to be formed for use in straight walls and curved walls. The final configuration (straight or curved) is fixed by field-installed fasteners to mechanically attach the steel strap to the angle flange or by activating “Hammerlock” tabs in the overlapping portions of the web of the steel angle segments. The 3⁵/₈-16 Flex-C Angle is similar to the 2¹/₂-20L and 2¹/₂-20 Flex-C Angles, except the 3⁵/₈-16 Flex-C Angle has an integral strap extended from the flange of the angle. See the illustration in Figures 4 and 5 for additional descriptive information.

3.2 Materials:

3.2.1 Flex-C Trac: The 2¹/₂-20L, 3⁵/₈-20L, 2¹/₂-20, 3⁵/₈-20, 4.0-20, 6.0-20, 8.0-20, and 10.0-20 Flex-C Tracs are formed from steel conforming to ASTM A653 SS Grade 33 and have a G40 or A40 or better galvanized coating. Refer to Table 1 for the specified base-steel thickness for each of these Flex-C Trac products.

The 3⁵/₈-18, 4.0-18, 6.0-18, 8.0-18, and 10.0-18 Flex-C Tracs are formed from steel conforming to ASTM A653 SS Grade 50 and have a G40 or A40 or better galvanized coating. Table 1 lists the specified base-steel thickness for each of these Flex-C Trac products.

The 3⁵/₈-16, 4.0-16, 6.0-16, 8.0-16, and 10.0-16 Flex-C Tracs are formed from steel conforming to ASTM A653 SS Grade 50 and have a G40 or A40 or better

galvanized coating. See Table 1 for the specified base-steel thickness for each of these Flex-C Trac products.

3.2.2 Flex-C Angle: The 2¹/₂-20L and 2¹/₂-20 Flex-C Angles are formed from steel conforming to ASTM A653 SS Grade 33 and have a G40 or A40 or better galvanized coating. The 3⁵/₈-16 Flex-C Angles are formed from steel conforming to ASTM A653 SS Grade 33, and have a G40 or A40 or better galvanized coating. Refer to Table 1 for the specified base-steel thickness of these angles.

3.2.3 Straps: The straps woven into the flanges of the Flex-C Tracs and Flex-C Angles are 0.75 inch (19.1 mm) wide and have a base-steel thickness of 0.023 inch (0.584 mm) and a G60 galvanized coating. The straps are formed from steel conforming to ASTM A653 Structural Steel Grade 80.

3.2.4 Studs: The studs must be C-shaped cold-formed steel studs having minimum base-steel thicknesses noted in Table 1 and depths noted in Section 3.1.1. The minimum flange width of the steel studs must be 1⁵/₈ inches (41.3 mm). The steel must conform to ASTM A653 SS Grade 50 and have a G40 or A40 or better galvanized coating.

3.2.5 Fasteners: The screws field-installed to attach the straps to the flanges of Flex-C Tracs and Flex-C Angles and to attach Flex-C Tracs and Flex-C Angles to steel wall studs must be as noted in Table 1. The bolts field-installed into the webs of Flex-C Tracs and Flex-C Angles to attach them to the supporting structures must be spaced at 16 inches (406 mm) or 17 inches on center and designed to sustain the applied load to the satisfaction of code official.

4.0 DESIGN AND INSTALLATION

4.1 Design:

The nominal loads of the Flex-C Trac and Flex-C Angle segments subjected to wall stud end reaction loads due to transverse loads applied to the wall framing, are indicated in Table 1. For use in design, the tabulated nominal loads must be modified as noted in footnote 1 of Table 1 to determine the ASD allowable load or LRFD design load. At the ASD allowable load the maximum deflection of the Flex-C Trac and Flex-C Angle installed with the Hammerlock tab connections (Method A) will not exceed 0.094 inches (2.38 mm) and the maximum deflection of the Flex-C Trac and Flex-C Angle installed with the side screw connections (Method B) will not exceed 0.125 inch (3.18 mm).

4.2 Installation:

The curvature of the Flex-C Trac and Flex-C Angle must be fixed by activating the "Hammerlock" (Method A) by striking down the "Hammerlock" tabs to create a connection such that the upper surface of the lower web/tab is coplanar with the upper surface of the upper web of the channels and angles, or by field-installing fasteners described in Section 3.2.3 into the straps at each flange of each segment of the channel (Method B).

The Flex-C Trac and Flex-C Angle must be attached to the supporting structure with fasteners installed through the web of the channel within 8 inches (203 mm) from each stud web, at approximately mid-depth of the channel or angle. The fasteners used to attach the Flex-C Trac and Flex-C Angle to the supporting structure shall be designed for the applied loads.

The wall framing studs must be installed into tracks such that the web of the stud is within 8 inches (203 mm)

of the fasteners attaching the track to the supporting structure. The wall framing stud installation locations must also be limited such that the loops in the Flex-C Trac flanges for the straps are not in the same location as the flanges of wall studs. Where the Flex-C Trac or Flex-C Angle is butt-spliced at adjacent tracks, the wall studs must not be installed between the butt splice and the fastener used to attach the Flex-C Trac and Flex-C Angle to the supporting structure. The studs must be affixed to the Flex-C Trac or Flex-C Angle with the fasteners described in Section 3.2.3 installed through the channel flange and/or steel strap and into the stud. The distance between the end of stud and web of Flex-C Tracs and Angles must be within 0.25 inch (6.35 mm) when Flex-C Tracs and Angles are used in non-load bearing walls framed with light gage cold-formed steel studs.

5.0 CONDITIONS OF USE

The Flex-C Tracs and Flex-C Angles described in this report comply with, or are suitable alternatives to what is specified in, those codes listed in Section 1.0 of this report, subject to the following conditions:

- 5.1 Flex-C Tracs and Flex-C Angles must be installed and identified in accordance with this report, the applicable code and the manufacturer's published installation instructions.
- 5.2 The ASD allowable loads or LRFD design loads derived in accordance with Footnote 1 to Table 1 must exceed the applied loads.
- 5.3 Complete plans, details, and calculations for each project, verifying compliance with this report, must be submitted to code official for approval.
- 5.4 The uncoated minimum base-steel thickness values for Flex-C Tracs and Flex-C Angles must be the minimum base-steel thickness values noted in Table 1.
- 5.5 Flex-C Tracs and Flex-C Angles are used to support steel studs designed without considering composite interaction between the wall sheathing and steel wall framing.

6.0 EVIDENCE SUBMITTED

Descriptive information, reports of load tests, and quality control documentation.

7.0 IDENTIFICATION

- 7.1 Each Flex-C Trac and Flex-C Angle is identified by the registered trademark of Flex-Ability Concepts, LLC, which is the word "Flex-C"; the serial/heat number; the part number; the company name and website address of Flex-Ability Concepts, LLC; and the evaluation report number (ESR-2306), stamped on the center of the web of each channel or angle segment.
- 7.2 The report holder's contact information is the following:

FLEX-ABILITY CONCEPTS
5500 RENO AVENUE, SUITE 300
OKLAHOMA CITY, OKLAHOMA 73127
(405) 996-5343
(866) 443-3539
www.flexabilityconcepts.com

TABLE 1—FLEX-C TRAC AND FLEX-C ANGLE DESIGN PARAMETERS AND NOMINAL LOADS^{1,2,5,6} (pounds)

PART NUMBER	NOMINAL TRAC OR ANGLE WEB DEPTH (in.)	MINIMUM BASE-STEEL THICKNESS (in.)		FASTENERS ³		METHOD OF FIXING CURVATURE ⁴			
		Trac or Angle	Stud ⁷	Strap to Flange	Trac or Angle to Studs	Method A		Method B	
						Load	Ω	Load	Ω
Flex-C Trac									
2.5-20L	2.5	0.028	0.028	No. 8-18	No. 8-18	172	2.90	442	2.90
3.625-20L	3.625	0.028	0.028	No. 8-18	No. 8-18	288	2.67	744	2.90
2.5-20	2.5	0.030	0.030	No. 8-18	No. 8-18	241	2.90	539	2.90
3.625-20	3.625	0.030	0.030	No. 8-18	No. 8-18	270	2.90	699	2.90
4.0-20	4.0	0.033	0.033	No. 8-18	No. 8-18	357	4.65	578	3.10
6.0-20	6.0	0.033	0.033	No. 8-18	No. 8-18	417	2.90	611	2.90
8.0-20	8.0	0.033	0.033	No. 8-18	No. 8-18	535	2.90	648	2.90
10.0-20	10.0	0.033	0.033	No. 8-18	No. 8-18	404	3.38	697	2.90
3.625-18	3.625	0.0428	0.0428	No. 8-18	No. 10-16	649	4.00	1,000	3.40
4.0-18	4.0	0.0428	0.0428	No. 10-16	No. 10-16	636	2.90	1,111	2.90
6.0-18	6.0	0.0428	0.0428	No. 10-16	No. 10-16	758	2.90	1,678	2.90
8.0-18	8.0	0.0428	0.0428	No. 10-16	No. 10-16	1,552	2.90	1,544	3.11
10.0-18	10.0	0.0428	0.0428	No. 10-16	No. 10-16	1,179	2.90	1,278	2.90
3.625-16	3.625	0.054	0.054	No. 8-18	No. 10-16	823	3.10	895	2.95
4.0-16	4.0	0.054	0.054	No. 10-16	No. 10-16	713	2.90	1,285	2.90
6.0-16	6.0	0.054	0.054	No. 10-16	No. 10-16	1,081	2.90	1,538	2.90
8.0-16	8.0	0.054	0.054	No. 10-16	No. 10-16	1,154	2.90	1,359	2.90
10.0-16	10.0	0.054	0.054	No. 10-16	No. 10-16	1,558	2.90	1,717	3.03
Flex-C Angle									
2.5-20L	2.5	0.028	0.028	No. 8-18	No. 8-18	110	2.90	90	3.10
2.5-20	2.5	0.030	0.030	No. 8-18	No. 8-18	191	2.90	124	2.90
3.625-16	3.625	0.054	0.054	No. 8-18	No. 10-16	385	2.90	282	2.90

For SI: 1 inch = 25.4 mm, 1 lbf = 4.45 N.

¹The tabulated nominal loads are the adjusted maximum stud reactions that can be supported by Flex-C Trac and Flex-C Angle segments. For allowable strength design (ASD), the allowable load for each model of Flex-C Trac and Flex-C Angle segment must be derived by dividing the associated adjusted nominal load by the associated safety factor, Ω, noted in the above table. The safety factor, Ω, values are derived in accordance with Chapter F of AISI S100-2007.

²For Flex-C Angle, the applicable load direction is perpendicular to, and towards, the vertical flange of the Flex-C Angle.

³The fastener length is, respectively, 0.5 inch for No. 8-18 and 0.75 inch for No. 10-16 pancake head self-drilling screws.

⁴The methods used to fix the curvature of the Flex-C Tracs or Flex-C Angles are described in Section 4.2.

⁵The flanges of track sections having the Hammerlock tab connections, Method A, will not exceed the out of wall plane deflection of 0.094 inch (2.38 mm) under allowable loads calculated in accordance with Table 1.

⁶The flanges of track sections having the side screw connections, Method B, will not exceed the out of wall plane deflection of 0.125 inch (3.18 mm) under allowable loads calculated in accordance with Table 1.

⁷The minimum base-steel thickness values for studs were used to generate the adjusted maximum tested stud reactions noted in the above table. The studs must be designed in accordance with AISI S211-2007.

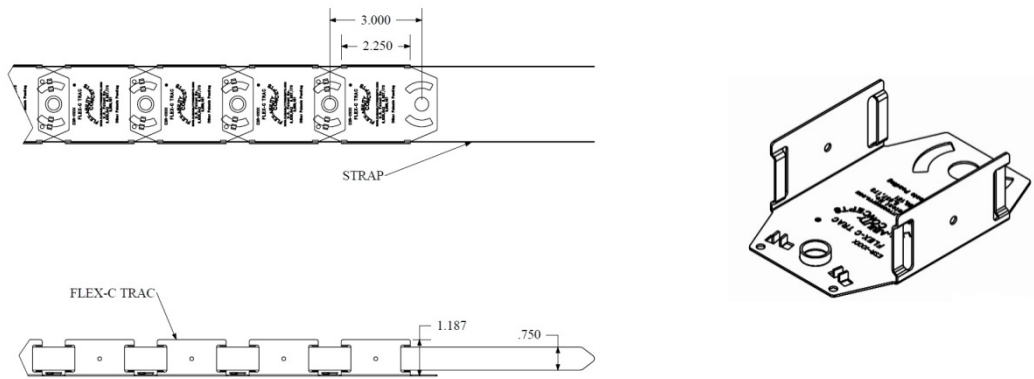

FIGURE 1—TYPICAL DRAWING OF FLEX-C TRAC AND ASSEMBLY OF FLEX-C TRACS WITH STEEL STRAPS

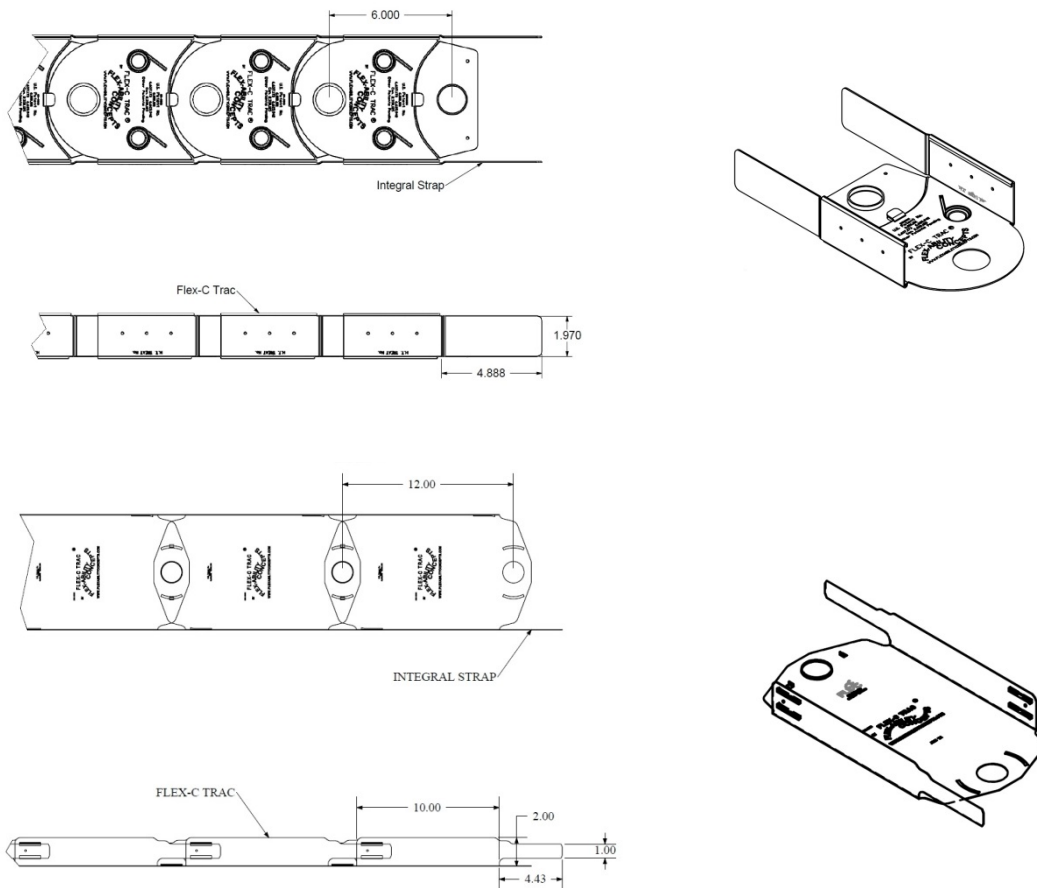

FIGURE 2—TYPICAL DRAWINGS OF FLEX-C TRACS AND ASSEMBLY OF FLEX-C TRACS WITH INTEGRAL STEEL STRAPS

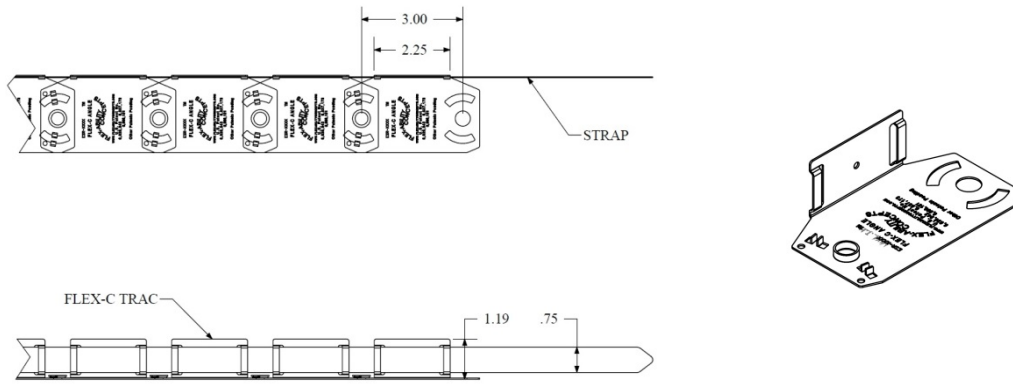

FIGURE 3—TYPICAL 2¹/₂-20L AND 2¹/₂-20 FLEX-C ANGLE AND ASSEMBLY OF FLEX-C ANGLES WITH INTEGRAL STEELSTRAPS STRAPS

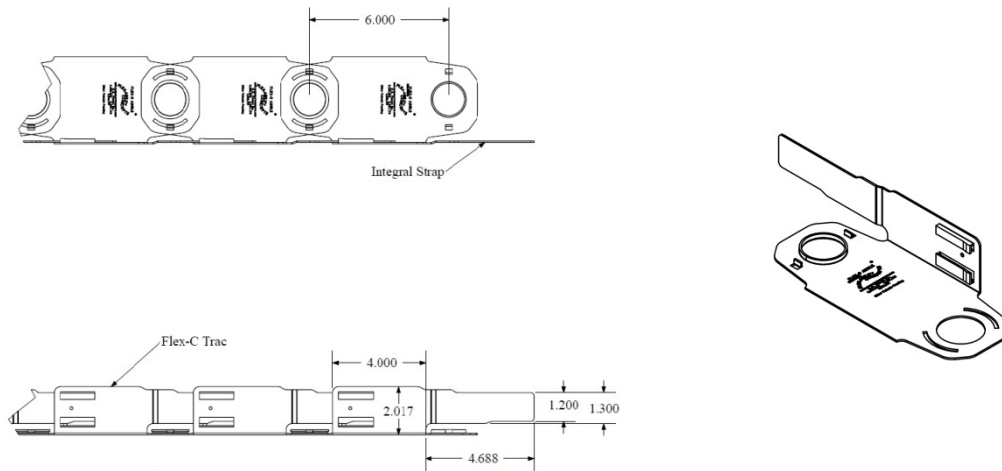

FIGURE 4—TYPICAL 3⁵/₈-16 FLEX-C ANGLE AND ASSEMBLY OF FLEX-C ANGLES WITH INTEGRAL STEEL STRAPS